



CARLOR
ENGINEERING

History

Carlor Engineering, ISO 9001 certified Belgian manufacturer, it is 15 years experience in the development of electric coolant heaters for all types of water-cooled engines. Carlor Engineering quickly became the leader in this field with the assets of a small company: reactivity, adaptation to market demand, quality and reliability.



TOP START

Preheating system with pump

4 to 12kW

The **TopStart** is an electric coolant heater for all types of water-cooled engines. It is universal, reliable, easy-to-install and maintenance-free.

The 4-12 kW heaters are suited for large industrial engines in both stationary (generator sets) and mobile applications (generator sets, diesel locomotives). The heater can be put into service a few hours before starting the engine, in order to keep the engine permanently at the required temperature. This ensures an easy full power start whatever the ambient temperature and avoids cold start mechanical damage.

The system has also following advantages: fuel savings, decreasing pollution, reduced engine wear, no more difficult cold starts, vehicle cab heater instantly operational.

EAC CE



Product benefits

- Strong die-casted aluminium body 100% recyclable
- Very compact product with integrated circulating pump for quick and homogeneous preheating
- Integrated circulating pump saving electricity and improving the life cycle of engine components
- Heating element with top-quality shielding and low specific power, increasing its life-cycle and that of the coolant
- Control thermostat with high cutout power for an optimised life cycle
- Safety thermostat with manual re-set option to protect the heating element if water levels in the circuit are low or if the control thermostat fails
- High waterproofness
- Easy replacement of parts
- Two years warranty on labour and spare parts

APPLICATIONS





CARLOR
ENGINEERING

TOP START
Preheating system with pump

4 to 12kW

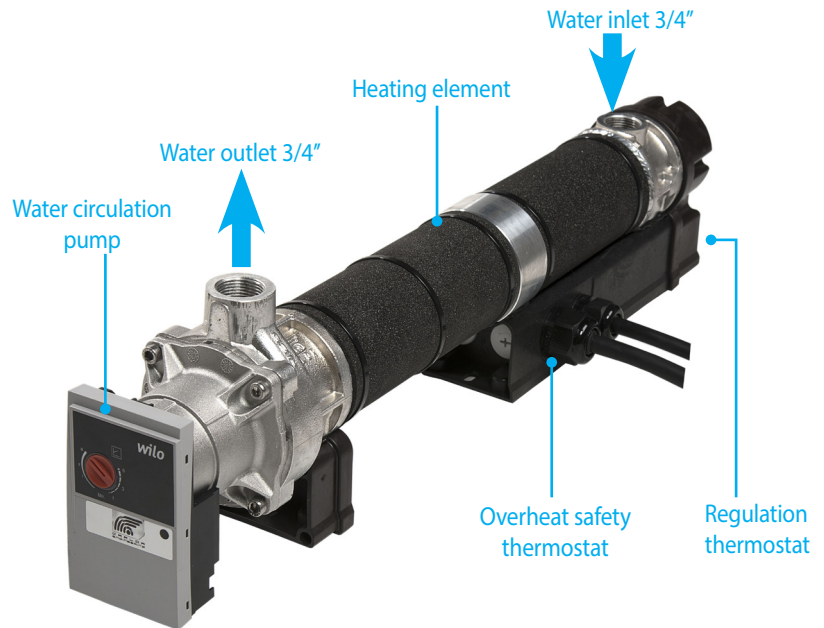
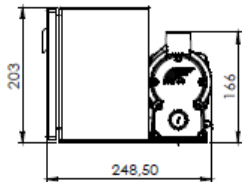
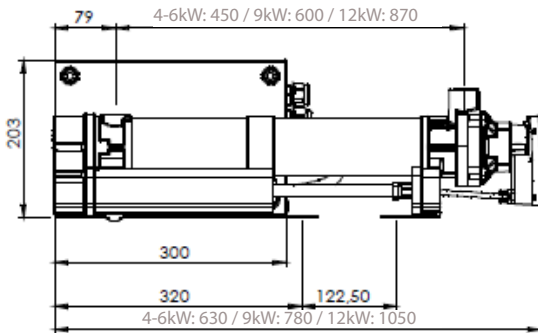
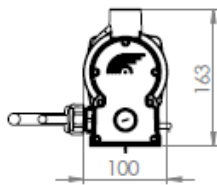
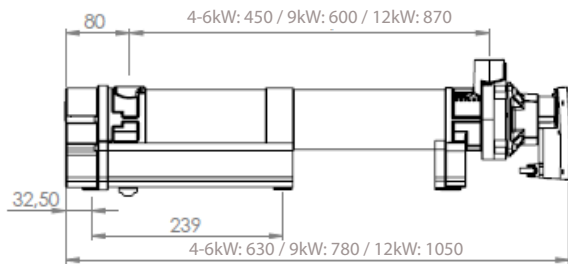

DELIVERED WITH CONNECTION KIT AND FIXATION KIT.

Connection kit



Fixation kit



Weight TopStart 4 - 6 kW: 6,5 Kg
Weight TopStart 9 kW: 7,5 Kg
Weight TopStart 12 kW: 8,6 Kg

CONTROL BOX (230V / 3*400V + N)

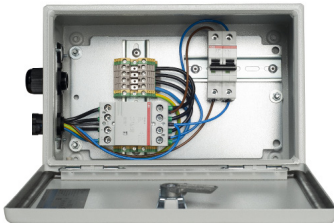

Weight: 5,5 kg

CONTROL BOX (3 * 400 V / 3*480V)

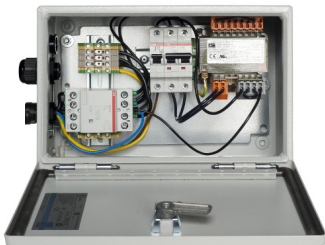

Weight: 7,5 Kg

Technical characteristics

HEATING UNIT

- Die casted aluminium body
- PA66 protection covers and support base
- 150 cm power cable
- 3/4" water outlet and inlet + connection kit

CIRCULATING PUMP

- Glandless circulation pump
- Max. flowrate: 1.6 to 2m³/h to 3m height
- manometer
- Adjustable speed
- Available voltage: 120V or 230V
- Available frequencies: 50 Hz or 60 Hz

WATER TEMPERATURE CONTROL THERMOSTAT

- Adjustable thermostat 0-80°C rated 25A, 100.000 cycles
- Available temperature interval: 0°C - 80°C (32°F - 176°F)

SAFETY THERMOSTAT

- Security thermostat with manual reset, rated 25A, 6.000 cycles (110 °C / 230°F)

HEATING ELEMENT

- Low watt density heating element made of Incoloy 800 (7,5W / cm²) what increases its lifetime and those of the coolant
- Available powers: 4 Kw - 12 Kw
- Available voltages: 230V / 400V / 440V / 480V / 690V

CONTROL TERMINAL (OPTION), AVAILABLE VOLTAGES

- 3*400 V 3*480V
- 3*400V + N, 1*230V
- 3*600V

