

HT-175 Series

Features and Benefits

- Mounts on the pump in place of mechanical governor
- Capable of controlling pumps on engines up to 12-cyl.
- Sealed to protect linkage and electromechanical components
- Connects directly to the fuel rack bellows
- Includes manual shut-off mechanism
- Compact size, fast response
- Cost effective design
- Feedback position available



The Integral Electric Actuator for Diesel Pumps

The HT-175 electric actuator is designed to mount directly to inline fuel injection pumps, with a right hand rack in place of the mechanical governor. An optional external fuel shut off lever is provided to manually override the actuator's control. Also provided, as standard equipment, is an adjustable internal maximum fuel limit.

The HT-175 Electric Actuator can control fuel pumps up to 12 cylinders. The actuator was designed with two isolated chambers. The upper chamber is wet with oil and contains the connection to the fuel rack and an optional manual shut off mechanism. The sealed lower chamber contains the electromagnetic components.

Preparing the fuel injection pump

If the fuel injection pump is equipped with a mechanical governor, it must be removed. Huegli Tech recommends that this modification be performed by a qualified fuel injection service facility. The following procedure lists the general steps required to remove the mechanical governor.

NOTE: Be prepared to collect the oil that will be released from the mechanical governor.

1. Remove the rear housing from the mechanical governor and disconnect the governor linkage from the pump fuel rack. Remove the flyweight assembly. A special tool is required.
2. Remove the intermediate governor housing. This leaves only the rack and camshaft protruding from the pump.
3. Install the adapter plate to provide the transition required from the actuator to the mounting holes formerly held by the governor housing. This plate must have countersunk holes for the mounting screws.

Installing the Actuator

1. Slip the spring seat Nr:20 over the fuel rack and press it into the seat hole of the fuel pump (Refer to Illustration 1-1); and put return spring Nr:19 onto the fuel rack, and push them into the spring seat of the fuel pump. Support the return spring with partNr:17, Nr:16, Nr:9 and Nr:10 of the connecting screw rod, and apply Loctite 243 onto flat round-headed M5x10 boltNr:18 and firmly tighten them on the fuel rack with 3.5 Nm torque. Note that the tab of the manual stop plate must face upward.
2. Remove the small cover plate Nr:2 and sealing ring Nr:4 of the actuator. Clean both mating end surfaces between the actuator and the fuel pump. onto two pieces Take the two M6x20 Allen screws Nr:6 and put on spring washer Nr:7 and plain washer Nr:11 and insert them into the two installation holes on the upper cavity of the actuator and apply Loctite 243 to the two M6x20. Insert the sealing ring Nr:8 into the sealing groove on the end surface of the actuator (Refer to Illustration 1-1 and Illustration 1-4), then carefully slide the actuator over the fuel rack through the upper chamber with the two M6x20 aligning with the mounting screw holes of the fuel pump; use the allen key with ball head into the upper cavityNr:24, and align the screws M6x20 Nr:6 and tighten with 5.5 Nm torque in sequence;
3. Carefully loosen bolt Nr:28 and nut Nr:25 to install the bearing so the bolt holding the bearing can freely move in the adjustment groove of the lever (Refer to Illustration 1-2); Turn the lever Nr:24 outward, until the armature touches the large cover plate Nr:14 and is kept in this position; move bearing assembly Nr:26 inward and press until the bearing touches the fuel rack screw Nr:10, continue pushing so the fuel rack is moving from stop fuel inward approx.: 1 – 2 mm. With this position kept, tighten bolt Nr:28 and nut Nr:25 with a torque of 3.5 Nm. The fuel rack is now released and the stop position is within the armature in order to prevent the fuel elements from damage.
4. Check the installation of the entire assembly, and ensure that all the bolts are tightened correctly. Push and pull the fuel lever and ensure it moves freely. Push the fuel rack lever to max position and make sure that the fuel rack is pushed back with the stop lever Nr:5 to full sop position.

5. The fuel lever Nr:24 is equipped with a max. fuel limit screw Nr:22, which is used to set the maximum fuel supply to the fuel pump. By adjusting this bolt, the maximum movement position for fuel lever is set and will limit the fuel rack position to max fuel.

NOTE: When installed, the cover must not hit the internal operating lever or the maximum fuel adjustment screw. Torque the cover screws to 2-3 NM. Check for any oil leaks. Lock-wire the lower screws for tamper resistance.

Warning

Setting high fuel levels may cause the maximum fuel adjustment screw to hit the inside of the top cover, which can change the minimum fuel position. This could lead to a dangerous condition. When setting fuel levels above 17mm of rack travel, ensure that the adjustment screw does not contact the cover at minimum fuel position.

With the fuel pump operating on the engine, the maximum fuel setting screw can be adjusted to provide specific horsepower.

Caution

The engine should be equipped with an independent shut down device to prevent overspeed which can cause equipment damage or personal injury.

Selection Chart

	12V	24V	w/ Shutoff	w/o Shutoff	w/ Mating Conn	w/o Mating Conn
HT-175A-12	*		*			*
HT-175A-24		*	*			*

Table A

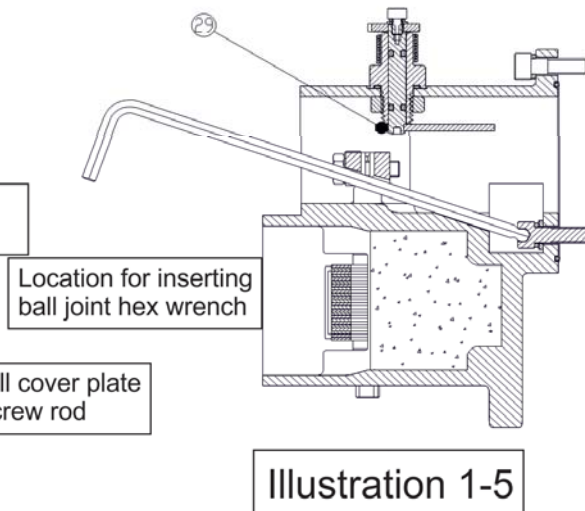
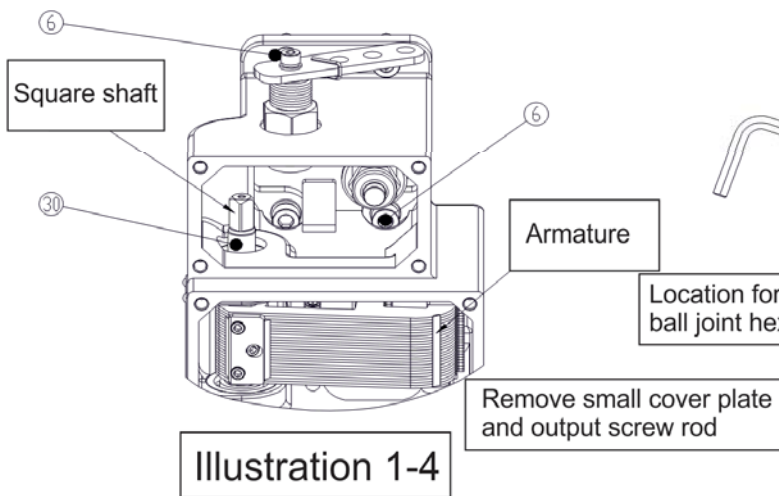
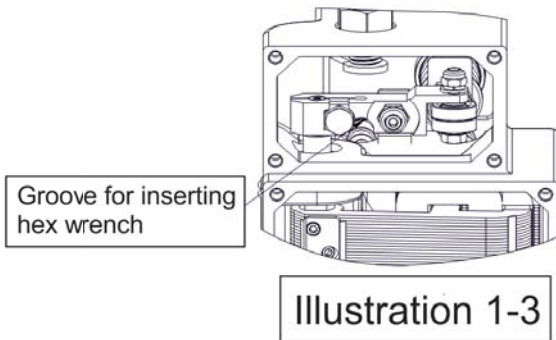
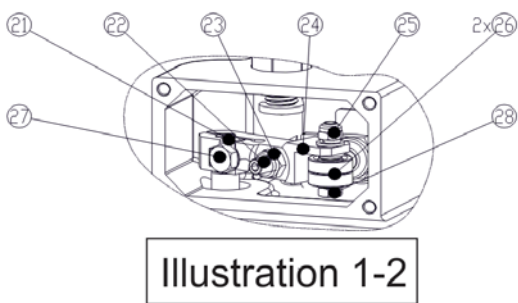
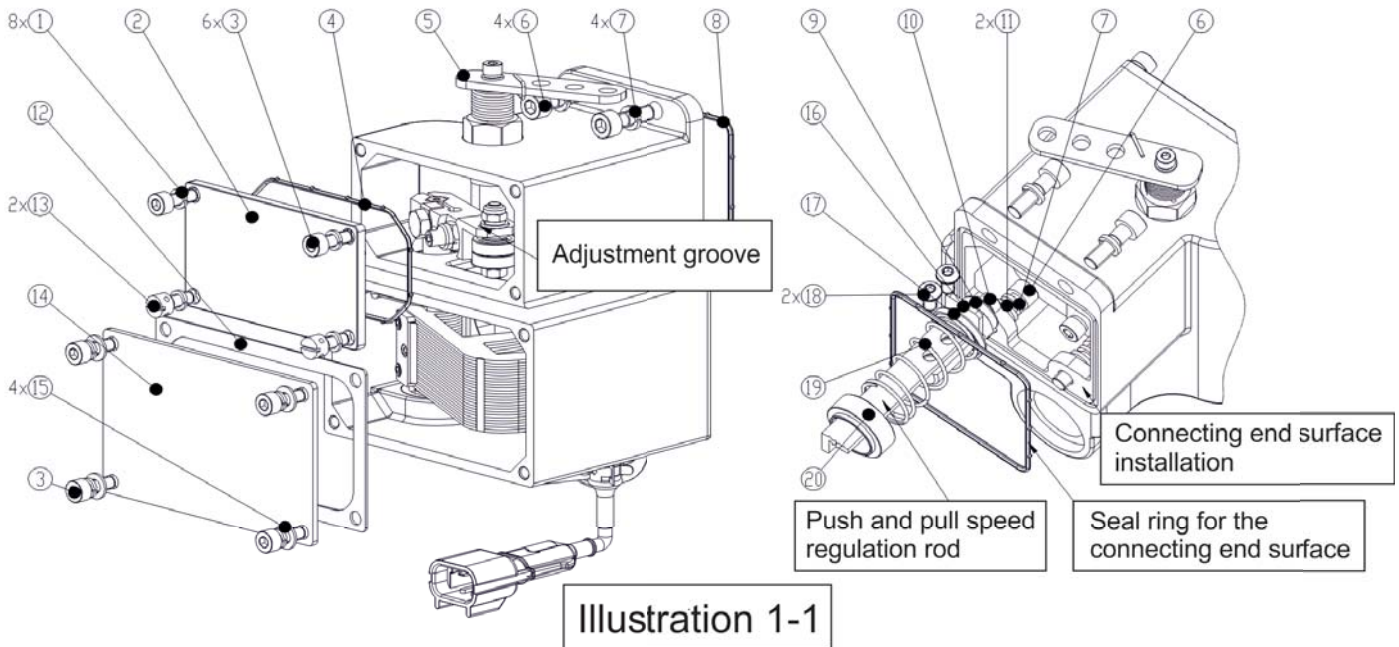

Dimensions

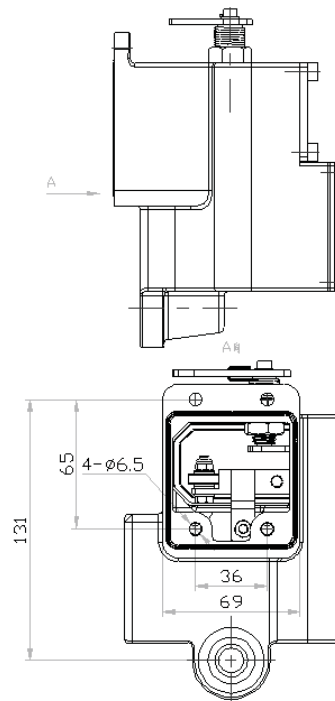
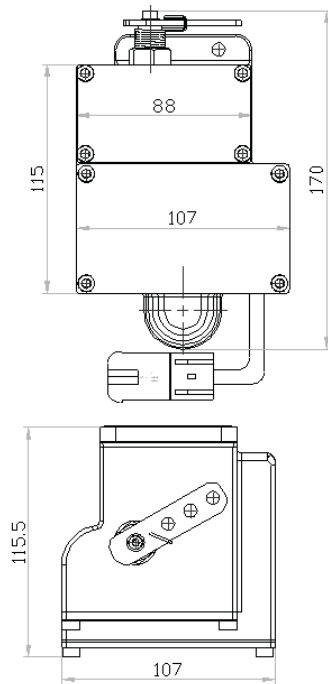

Specification

Performance

Force.....	6.2 lbs (27.5N)
Operating Stroke.....	0.80 in (21mm)
Response Time (10-90% 2-19mm).....	35 MSEC
Internal Sealing Pressure.....	2 bar (29 psi)

Electrical Power Input

Operating Voltage.....	12 VDC or 24 VDC
Coil Resistance.....	12 VDC Version- 1.7+/-0.2 OHMS
.....	24 VDC Version- 7.2+/-0.5 OHMS
Nominal Operating Current.....	12 VDC Version- 4.0 A
.....	24 VDC Version- 2.0 A
Maximum Current.....	12 VDC Version- 5.8 A
.....	24 VDC Version- 3.1 A

Environmental

Operating Temperature.....	-40° to +200°F (-40° to +95°C)
Relative Humidity.....	Up to 100%
Shock.....	20g @11msec
Vibration.....	20g, 20-500 Hz
Agency.....	RoHS Compliant

Physical

Dimensions.....	See Figure 2-1
Weight.....	4.75 lbs. (2.2 kg)
Mounting.....	adapter plate
Finish Specification.....	ES1031
Mating Cable Harness.....	CH1220LX

Local Distributor / Partner:

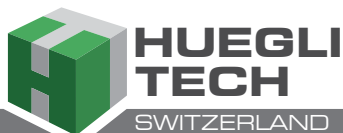

HUEGLI TECH AG (LTD)
Murgenthalstrasse 30
4900 Langenthal Switzerland
Phone: +41 62 916 50 30
Fax: +41 62 916 50 35

e-mail: sales@huegli-tech.com
www.huegli-tech.com