

Electronic Gas Engine Speed Governor

HT-SG-100-H

Benefits

- H-Bridge driver Output
- Suits 12/24 VDC systems
- IP65 sealed
- Bi-directional CAN Bus enabled
- Clear LED Display (RPM default)
- Simple 3-button Interface
- RPM sent as std. J1939 value
- Idle speed
- Overspeed Protection
Sent as std. J1939 FMI code
- Speed Ramp
- Fuel Ramp
- Crank Termination
- Start Fuel Position
- Fuel Limit
- 3 Speeds
- Variable Speed
- Droop
- Multi PID settings
- Acceleration
- Deceleration
- Synch/Load-sharing
via 0-10V analogue input or
J1939 SpeedUP/SpeedDown
- External Speed Trim
- Position Mode

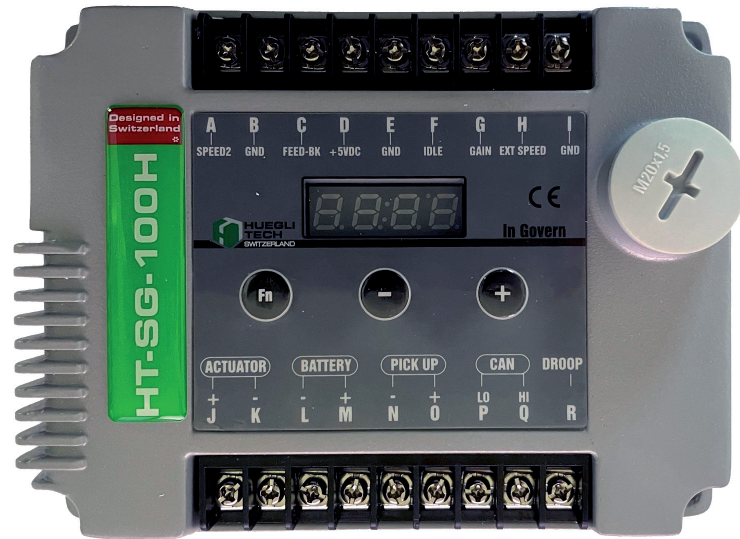

Smart Governing

The **HT-SG-100-H** is an electronic speed governor especially suited to gas engines. Its digital processing not only provides flexibility in configuration but also allows CAN J1939 data exchange with many modern controllers.

The unit will internally convert the signal from a standard inductive flywheel pick-up to an RPM value, display it on the 4-digit LED display and also send it as a standard J1939 value to a connected controller.

If the RPM exceeds the set Overspeed value, the unit sends the standard J1939 FMI code in addition to cutting current to the actuator.

The unit's desired speed can also be set by standard J1939 SpeedUp/SpeedDown commands over the CAN Bus connection as well as by a conventional 0-10V synchronizing and load sharing signal input.

This J1939 integration simplifies the wiring, saves installation time and allows implementation of more sophisticated controller features.

InGovern smart speed controllers are fully potted for sealing and vibration resistance and suitable for mounting on or close to a running engine. They provide precise (<0.25%) isochronous rotational speed control.

The **HT-SG-100-H** is supplied pre-configured and once the number of flywheel teeth is input (1 x press of [Fn] button then [+] or [-] until the correct value is displayed) then the engine will run. All parameters are stored in non-volatile memory.

Fine tuning of the main PID loop and other common features can be done using the same 3 buttons on the front panel. The supplied PC software (which connects via a standard USB cable – no dongle required) provides an overview of all settings, allows user-friendly PID adjustment on a running engine and allows access to secondary parameters including a second PID loop.

The final configuration can be saved and downloaded to other **HT-SG-100-Hs** for multiple engine applications or for series production.

Technical Specification

Safety instructions and Warnings

Before installing and starting the device, please read the operating instructions. These contain important notes for safety and use.

No liability can be accepted for damage arising from failure to follow the instructions or any inappropriate use.

The governor may only be used for the manner of operation prescribed in the operating instructions and only in connection with third-party devices and components recommended or installed by us or software supplied by us.

Any other use shall be considered inappropriate use and will result in the voiding of all liability and warranty claims against the manufacturer. Interventions and alterations that influence the safety technology and the functionality of the governor may be carried out only by the manufacturer. Fault-free and safe operation is conditional upon competent transport, assembly and installation as well as qualified use and correct maintenance.

All relevant accident prevention regulations and other generally recognised technical safety and health and safety at work rules are to be observed. Fault-free functioning of the machinery and its peripheral components is only guaranteed with original accessory parts and spare parts. The **HT-SG-100-H** engine speed governor is robust enough to be placed in a control cabinet with other operating control devices or installed on the engine. If water, mist or condensation can come into contact with the controller, it should be mounted vertically, allowing the liquid to flow away from the controller. Extremes of heat should be avoided.

Overspeed protection

i **IMPORTANT**

An overspeed shut down mechanism must be installed separately from the control system as a safety measure, to prevent engine faults that may result in damage or injury to machinery or persons. A secondary shut down device (e.g. air shut-off valve) must be installed.

Installation and connection

General information

The pick-up cable should be shielded to guarantee that no electromagnetic interference can reach and affect the engine speed governor reading.

The shield should be connected to the battery negative.

To maintain the correct distance between the flywheel and the RPM sensor, the sensor must be rotated in until the flywheel touches and then rotated out again for $\frac{3}{4}$ of a rotation. This achieves the correct spacing between flywheel and sensor. To be able to start the engine, the RPM sensor must generate at least 1V AC RMS during the start.

Cross-section of the battery and actuator cable at terminals A,B,C, and D:

1.5 mm² for 24 VDC or 2.5 mm² for 12 VDC

For longer cables (>5m) the cable cross-section is to be increased appropriately to keep the voltage drop low.

- Battery positive (+) input, connection M, should be fused 10 A.
- The governor should be installed such that the housing has connection with the chassis of the control cabinet.
- The cable of the actuator must be shielded along its entire length.
- The cable of the pick-up sensor must be shielded along its entire length.
- The cable of the variable RPM speed input can be up to 5m long. For longer cables, a shielded cable must be used.
- The shielding must always be grounded such that it does not come into contact with the chassis of the machine. This is to prevent stray signals from entering the governor and causing interference. The shield must be grounded at one end.

Connection terminals

Connection terminal	Description	Definition
A	SPEED2	Speed Selection 2
B	GND	Ground/chassis
C	FEED-BK	Actuator feedback
D	+5VDC	5VDC Supply (Feedback sensor)
E	GND	Ground
F	IDLE	Idle speed selection
G	GAIN	PID selection set A or B
H	EXT SPEED	Load distribution / synchronisation
I	GND	Ground
J	Actuator +	Actuator drive supply +ve
K	Actuator -	Actuator drive supply -ve
L	Battery -	System Power supply -ve
M	Battery +	System Power supply +ve
N	Pickup -	Pickup sensor -ve
O	Pickup +	Pickup sensor +ve
P	CAN low	CAN bus low
Q	CAN high	CAN bus high
R	DROOP	Droop

Electronic Gas Engine Speed Governor

HT-SG-100-H

Accessing the functions

In SETUP mode, the functions listed below can be accessed using the [Fn] button.

Each press of the [Fn] button makes the next menu active. The active menu is shown on the LED display for 2 seconds, after which the relevant value of this function appears.

Settings are changed with the arrow keys [-] [+] and raise/lower the value by 1.

If the arrow keys [-] [+] are held down longer, the value increases at a greater rate.

Regular Mode

Normal operating mode	1500	RPM	e.g. 1500 rpm
Press & Hold [Fn] and [+] button for 3 seconds	SPd.1/1500	Speed 2 value	e.g. 1500 rpm
Fn button: 1x press	GEAr/120	Number of teeth	e.g. 120 teeth
Fn button: 2x press	GAI/50.2	P value*	e.g. 50.20%
Fn button: 3x press	Int/21.9	I value*	e.g. 21.9%
Fn button: 4x press	dEr/7.0	D value*	e.g. 7.0%
Fn button: 5x press	Ltin/5	PID Loop time value	e.g. 5
Fn button: 6x press	CrAn/500	Crank-speed	e.g. 500 rpm
Fn button: 7x press	FurA/3	Fuel ramp	e.g. 3 sec.
Fn button: 8x press	SPrA/10	Speed ramp	e.g. 10 sec.
Fn button: 9x press	St.Po/50	Start Position	e.g. 50%
Fn button: 10x press	FuE.L/100	Fuel Limit	e.g. 100
Fn button: 11x press	o.SPd/2000	Over-speed	e.g. 2000 rpm
Fn button: 12x press	droo/3.0	Droop %	e.g. 3.0%
Fn button: 13x press	Ctrl/30	Chopper frequency	e.g. 30
Fn button: 14x press	1500	RPM display	e.g. 1500 rpm

[+] button: 1x press	2000 → 2001	Increase value by 1	for all parameters
[-] button: 1x press	2000 → 1999	Reduce value by 1	for all parameters
Press & Hold [Fn] button for 3 seconds to select Quick mode if required	qui	To select quick mode display	to access only PID Menus

*Display of the values is dependent on input G (Gain). If this is open, parameter set 1 (Gain 1, Int 1 and Der 1) is shown; if the input is closed, parameter set 2 (Gain 2, Int 2 and Der 2) is shown.

Quick Mode

Normal operating mode	1500	RPM	e.g. 1500rpm
[Fn] button: 1x press	GAI.1/50.2	P value*	e.g. 50.2 %
[Fn] button: 2x press	Int.1/21.9	I value*	e.g. 21.9 %
[Fn] button: 3x press	dEr.1/7.0	D value*	e.g. 7.0 %
[Fn] button: 4x press	Ltin/5	PID Loop Time value	e.g. 5
[Fn] button: 5x press	1500	RPM display	e.g. 1500rpm
Press & Hold [Fn] button for 3 seconds To select Regular mode if required	rEG	To select regular mode display	to access all the Menus

General Features for all Types and Modes

Press & Hold [+] and [-] button for 3 seconds to know the firmware version	v3.04	Working firmware version	Version 3.04
Press [Fn] and [-] button to exit from Menu display	1500	RPM display	e.g. 1500 rpm
[+] button: 1x press	2000 → 2001	Increase value by 1	for all parameters
[-] button: 1x press	2000 → 1999	Reduce value by 1	for all parameters

*Display of the values is dependent on input G (Gain). If this is open, parameter set 1 (Gain 1, Int 1 and Der 1) is shown; if the input is closed, parameter set 2 (Gain 2, Int 2 and Der 2) is shown.

Electronic Gas Engine Speed Governor

HT-SG-100-H

Hardware use (Keypad) and Dimensions

The **HT-SG-100-H** has three menu buttons, with which allows parameters to can be set locally. The set values are indicated on the LED display. In normal operating mode, the RPM is indicated on the display.

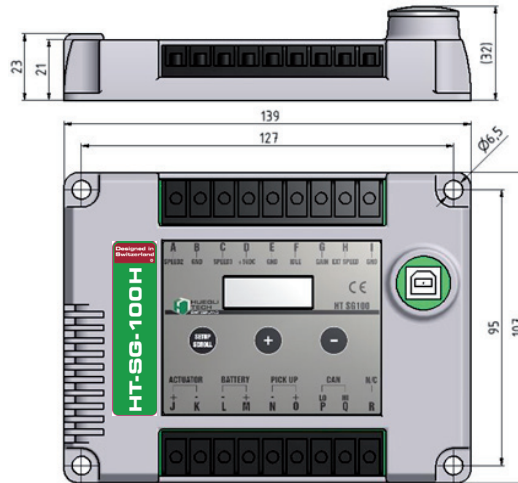

Wiring Diagram HT-SG-100-H

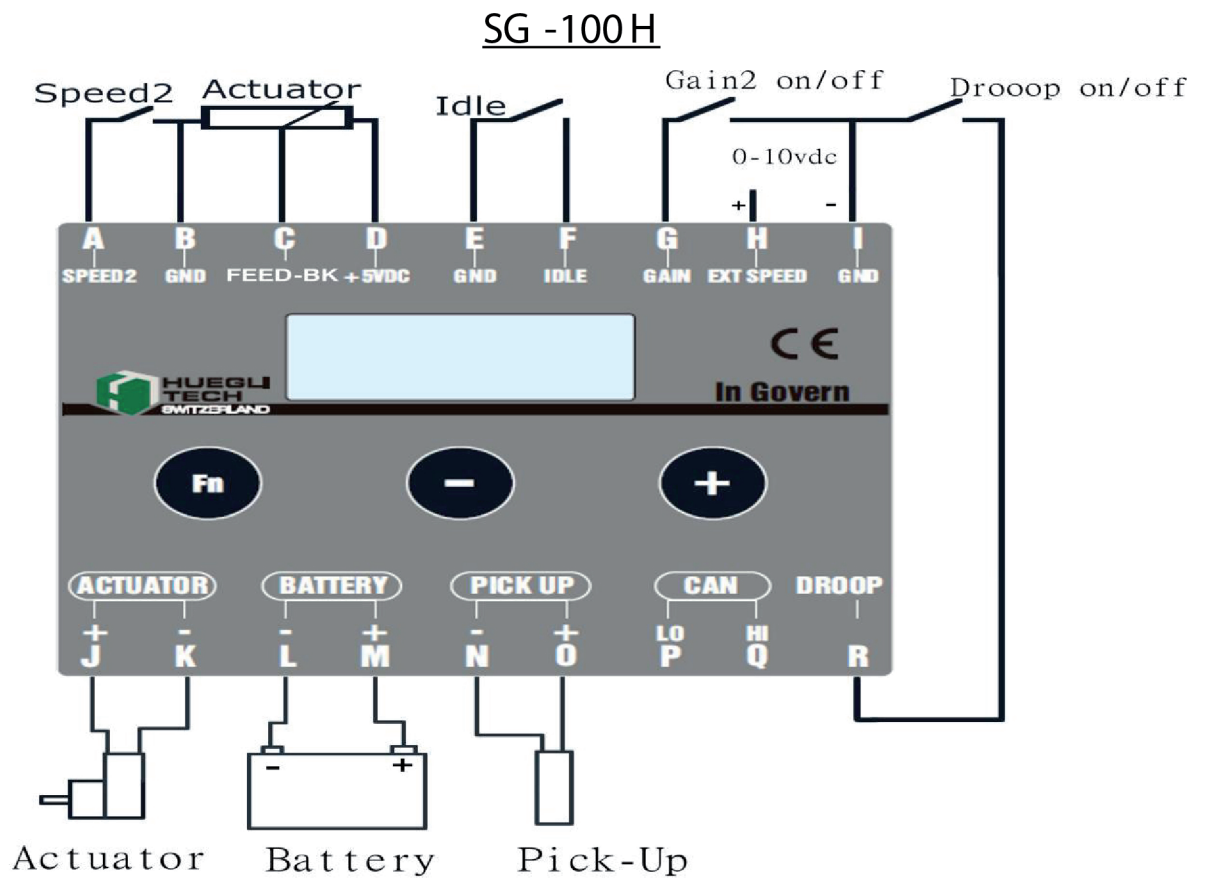

Cross-section of the battery and actuator cable at terminals L, M, J and K:

1.5 mm² for 24 VDC or
2.5 mm² for 12 VDC

Electronic Gas Engine Speed Governor

HT-SG-100-H

Technical Data

Performance

Isochronous/stability..... $\pm 0.25\%$
RPM range.....300 Hz - 8 KHz
(112-4000 RPM for flywheel with 160 teeth)
RPM variation with temperature..... $\pm 0.25\%$ max.
Idle adjustment.....Full Range
Speed Trim.....Programmable 0-100%, (default = 5%)

Surroundings

Temperature range..... -40° to 85°C (-40 to $+185^{\circ}\text{F}$)
Relative humidity.....up to 95%
Surface finish.....Fungus Proof and Corrosion Resistant
CE certificate..... EN61326-1

Input/output parameters

Supply voltage.....12 or 24 VDC Battery, (6.5 VDC to 33 VDC)
Polarity.....Negative Ground (housing isolated)
Current Consumption.....90 mA max. continuous,
(Excluding actuator drawn current)
Max permitted actuator current.....8 A continuous (at 25°C)
Engine speed sensor signal.....1 – 120 V RMS
+5VDC Output (Terminal D).....up to 12 mA
Load Share/Synchronizer Input.....0-10 VDC
(5V nominal, reversed, 5 rpm/V)
Reverse Power Protection.....Yes
Transient Voltage Protection.....60V

Norms/standards

Authorising office.....CE and RoHS requirements
Communication.....SAE J1939

Reliability

Vibration.....7G, 20-100 Hz
Shock.....20G Peak
Inspection.....100% functionality inspection

Mass and weight

Dimensions.....139 x 107 x 32 mm
Weight.....0.372 kg
Installation.....direct on engine chassis, preferably vertical,
with rubber shock absorbers, insulated,
or in control cabinet

Configuration parameters

Number of flywheel teeth, range.....50 - 255 teeth
Overspeed protection.....max. 4000 rpm
Starter cut-out speed.....4000 rpm*
Fixed RPM.....4000 rpm*
Variable RPM.....4000 rpm*
Prescribed start quantity.....0 - 100 %
Fuel Ramp.....0 - 20 sec.
Speed Ramp.....0 - 100 sec.

* Depending on Overspeed Protection.
These values are always < Overspeed.

Local Distributor / Partner:



HUEGLI TECH AG (LTD)
Murgenthalstrasse 30
4900 Langenthal Switzerland
Phone: +41 62 916 50 30
Fax: +41 62 916 50 35

e-mail: sales@huegli-tech.com
www.huegli-tech.com